

Residential Power Vent Gas Water Heater



Photo is of
RG1PV506N

The TTW[®] Models Feature:

- **ENERGY STAR[®] Qualified**—Some models meet or exceed requirements for ENERGY STAR[®] per the latest ENERGY STAR[®] criteria revision, as well as most utility rebate programs.
- **Powerful Blower Motor**—Exclusively featuring the AquaVENT MAX[™] from Fasco[™] is the quietest blower motor in the industry. This new blower is a lower profile than previous versions and features a more robust electrical connection.
 - Ten Foot (3 meter) Power Cord—Included (120 VAC).
- **Horizontal and Vertical Venting**—Designed for installations where atmospheric units cannot be used. Exhaust gases are vented under positive pressure directly out of the building through the roof or the wall with PVC, ABS or CPVC (Maximum equivalent vent length on reverse side).
- **Bradford White ICON System[®]**—Intelligent gas control with spark to pilot ignition system eliminates the constant burning pilot. This results in savings of pilot gas during standby periods (120 VAC).
 - **Enhanced Performance**—Proprietary algorithms provide enhanced First Hour Rating and tighter temperature differential.
 - **Advanced Temperature Control System**—Microprocessor constantly monitors and controls burner operation to maintain consistent and accurate water temperature levels.
 - **Intelligent Diagnostics**—An exclusive green LED light prompts the installer during start-up and provides ten different diagnostic codes to assist in troubleshooting.
 - **Pilot On Indication**—Flashing green LED provides positive indication that pilot is on.
 - **Separate Immersed Thermowell**—High-strength advanced polymer composite thermowell provides isolation between electric temperature sensor and surrounding water. No need to drain the tank when removing gas valve.
- **Advanced ScreenLok[®] Technology Flame Arrestor Design**—Flame arrestor is designed to prevent ignition of flammable vapor outside of the water heater (excluding RG1PV55H6N & RG2PV75H6N).
- **Flammable Vapor Sensor**—Electronic sensor prevents burner operation if flammable vapors are detected. The sensor will also prevent operation if there is ongoing flammable vapors burning inside the combustion chamber (excluding RG1PV55H6N & RG2PV75H6N).
- **Maintenance-Free**—No regular cleaning of air inlet openings or flame arrestor is required under normal conditions (excluding RG1PV55H6N & RG2PV75H6N).
- **Sight Window**—Offers a view into the combustion chamber to observe the operation of the pilot and burner.
- **Factory-Installed Hydrojet[®] Total Performance System**—Sediment reducing device that also increases first hour rating of hot water while minimizing temperature build-up in tank.
- **Vitraglas[®] Lining**—An exclusively engineered enamel formula that provides superior tank protection from the highly corrosive effects of hot water. This formula (Vitraglas[®]) is fused to the steel surface by firing at a temperature of over 1600°F (871°C).
- **Insulation System**—Non-CFC foam covers the sides and top of the tank, reducing heat loss. This results in less energy consumption, improved efficiencies, and jacket rigidity.
- **Water Connections**—3/4" (19mm) NPT factory-installed true dielectric fittings extend water heater life and simplify water line connections.
- **3/4" (19mm) NPT Side Connections**—(RG2PV50H6N, RG1PV55H6N, and RG2PV75H6N only).
- **Factory-Installed Heat Traps**—Design incorporates a flexible disk that reduces heat loss in piping and eliminates the potential for noise generation.
- **Protective Magnesium Rod**—(RG1PV55H6N has 2).
- **T&P Relief Valve**—Installed.
- **Thermostatic Mixing Valve (ASSE Approved)**—Included (RG1PV55H6N only).
- **Low Restrictive Brass Drain Valve**—Durable tamper proof design.
- **NOx Emissions**—Less than 40 ng/J.

FEATURING:



6 or 10-Year Limited Tank Warranties / 6 or 10-Year Limited Warranty on Component Parts.

For more information on warranty, please visit www.bradfordwhite.com

For products installed in USA, Canada, and Puerto Rico. Some states do not allow limitations on warranties. See complete copy of the warranty included with the heater.

Residential Power Vent Gas Water Heater

TTW® Power Vent Models

Meet or exceed ASHRAE 90.1b (current standard) C.E.C. Listed
80% Recovery Efficiency

NATURAL GAS AND LIQUID PROPANE GAS

Model Number	Nominal Gal. Capacity		DOE Rated Storage Volume (Gal.)	BTU/Hr. Input	LP BTU/Hr. Input	First Hour Rating (Gal.)	Uniform Energy Factor	Recovery at 90°F Rise*			Model Number	Nominal Liter Capacity	DOE Rated Storage Volume (Liters)	kW Input	LP kW Input	First Hour Rating (Liters)	Uniform Energy Factor	Recovery at 50°C Rise*		
	U.S. Gal.	Imp. Gal.						U.S. GPH	Imp. GPH	U.S. GPH								LP Imp. GPH	Liters/Hour	LP Liters/Hour
★ RG1PV40S6N	40	33	38	40,000	38,000	75	0.68	43	36	41	34	★ RG1PV40S6N	151	144	11.7	11.1	284	0.68	163	155
★ RG1PV50S6N	50	42	48	40,000	38,000	78	0.69	43	36	41	34	★ RG1PV50S6N	189	182	11.7	11.1	295	0.69	163	155
★ RG2PV40S6N	40	33	38	40,000	38,000	75	0.72	43	36	41	34	★ RG2PV40S6N	151	144	11.7	11.1	284	0.72	163	155
★ RG2PV50S6N	50	42	48	40,000	38,000	78	0.72	43	36	41	34	★ RG2PV50S6N	189	182	11.7	11.1	295	0.72	163	155
★ RG2PV40T6N	40	33	38	40,000	40,000	78	0.72	43	36	43	36	★ RG2PV40T6N	151	144	11.7	11.7	295	0.72	163	163
★ RG2PV50T6N	50	42	48	40,000	40,000	75	0.72	43	36	43	36	★ RG2PV50T6N	189	182	11.7	11.7	284	0.72	163	163
★ RG2PV50H6N	48	42	46	65,000	58,000	116	0.68	70	58	62	52	★ RG2PV50H6N	182	174	19.1	17.0	440	0.68	265	235
RG1PV55H6N	55	46	55	78,000	78,000	125	0.68	84	70	84	70	RG1PV55H6N	208	208	22.9	22.9	474	0.68	318	317
RG2PV75H6N	75	62	72	76,000	75,500	121	0.69	82	68	81	67	RG2PV75H6N	284	235	22.3	22.1	459	0.69	310	307

Model Number	A Floor to Top of Blower in.	B Jacket Dia. in.	C Vent Size in.	D Floor to T&P Conn. in.	E Floor to Gas Conn. in.	F Floor to Top of Heater in.	G Floor to Water Conn. in.	H Depth in.	J C/L of Water Conn. in.	K Floor to Space Heating Inlet in.	L Floor to Space Heating Outlet in.	M Water Conn. NPT in.	R Space Heating Conn. Size in.	S Gas Conn. Size in.	Approx. Shipping Weight lbs.
★ RG1PV40S6N	55 ⁷ / ₁₆	20	2 or 3	40	11 ¹ / ₂	46 ¹ / ₂	49	25 ¹⁵ / ₁₆	8	N/A	N/A	3/4	N/A	1/2	140
★ RG1PV50S6N	56 ³ / ₈	22	2 or 3	40 ⁵ / ₈	11 ¹ / ₂	48 ³ / ₁₆	50 ¹ / ₂	27 ³ / ₁₆	8	N/A	N/A	3/4	N/A	1/2	166
★ RG2PV40S6N	55 ⁷ / ₁₆	22	2 or 3	40 ¹ / ₈	11 ¹ / ₂	47 ³ / ₁₆	49	27 ³ / ₁₆	8	N/A	N/A	3/4	N/A	1/2	142
★ RG2PV50S6N	56 ⁷ / ₁₆	24	2 or 3	40 ⁵ / ₈	11 ¹ / ₂	48 ³ / ₁₆	50 ¹ / ₂	28 ⁷ / ₈	8	N/A	N/A	3/4	N/A	1/2	168
★ RG2PV40T6N	65	20	2 or 3	49 ¹¹ / ₁₆	11 ¹ / ₂	56 ³ / ₄	58	26 ¹ / ₈	8	N/A	N/A	3/4	N/A	1/2	146
★ RG2PV50T6N	65 ¹³ / ₁₆	22	2 or 3	50 ⁹ / ₁₆	11 ¹ / ₂	57 ⁹ / ₁₆	58	27 ³ / ₁₆	8	N/A	N/A	3/4	N/A	1/2	173
★ RG2PV50H6N	66 ¹ / ₂	22	3 or 4	49 ⁷ / ₈	11 ¹ / ₂	56 ³ / ₄	57 ³ / ₄	26 ¹⁵ / ₁₆	11	13 ³ / ₈	49 ⁷ / ₈	3/4	3/4	1/2	187
RG1PV55H6N	64 ⁹ / ₁₆	22	3 or 4	47 ¹⁵ / ₁₆	11 ¹ / ₂	54 ³ / ₄	56	27 ³ / ₁₆	7 ³ / ₄	13 ³ / ₈	47 ¹⁵ / ₁₆	3/4	3/4	1/2	219
RG2PV75H6N	69 ¹ / ₂	26	3 or 4	51 ¹⁵ / ₁₆	13 ¹⁵ / ₁₆	59 ¹¹ / ₁₆	60 ³ / ₄	30 ¹¹ / ₁₆	11	16 ¹¹ / ₁₆	51 ¹⁵ / ₁₆	3/4	3/4	1/2	260

Model Number	A Floor to Top of Blower mm.	B Jacket Dia. mm.	C Vent Size mm.	D Floor to T&P Conn. mm.	E Floor to Gas Conn. mm.	F Floor to Top of Heater mm.	G Floor to Water Conn. mm.	H Depth mm.	J C/L of Water Conn. mm.	K Floor to Space Heating Inlet mm.	L Floor to Space Heating Outlet mm.	M Water Conn. NPT mm.	R Space Heating Conn. Size mm.	S Gas Conn. Size mm.	Approx. Shipping Weight kg.
★ RG1PV40S6N	1408	508	51 or 76	1016	292	1181	1245	659	203	N/A	N/A	19	N/A	13	64
★ RG1PV50S6N	1432	559	51 or 76	1032	292	1224	1283	691	203	N/A	N/A	19	N/A	13	75
★ RG2PV40S6N	1408	559	51 or 76	1019	292	1199	1245	691	203	N/A	N/A	19	N/A	13	64
★ RG2PV50S6N	1408	610	51 or 76	1032	292	1244	1283	733	203	N/A	N/A	19	N/A	13	76
★ RG2PV40T6N	1651	508	51 or 76	1262	292	1441	1473	664	203	N/A	N/A	19	N/A	13	66
★ RG2PV50T6N	1672	559	51 or 76	1284	292	1462	1473	691	203	N/A	N/A	19	N/A	13	78
★ RG2PV50H6N	1689	559	76 or 102	1267	292	1441	1467	684	279	340	1267	19	19	13	85
RG1PV55H6N	1640	559	76 or 102	1218	292	1391	1422	691	197	340	1218	19	19	13	99
RG2PV75H6N	1689	660	76 or 102	1319	354	1516	1543	779	279	424	1319	19	19	13	118

Propane models feature a Titanium Stainless Steel propane burner. For Propane (LP) models change suffix "N" to "X". For 10 year models, change suffix from "6" to "10" (Not available on RG1PV55H6N). *Based on manufacturer's rated recovery efficiency. 120 VAC Required for Power Venting / 120 VAC, 60Hz., 3.1 Amperes. Uniform Energy Factor and First Hour Rating is based on the latest AHRI directory listings.

★ = ENERGY STAR® Qualified.



RG2PV40S6N RG2PV50S6N RG1PV40S6N	RG1PV50S6N RG2PV40T6N RG2PV50T6N	2" Vent Pipe	3" Vent Pipe	RG2PV50H6N RG1PV55H6N RG2PV75H6N	3" Vent Pipe	4" Vent Pipe
Max. Equivalent Length		†50 ft.	†120 ft.	Max. Equivalent Length		†50 ft. / †180 ft.
Min. Equivalent Length		7 ft.	15 ft.	Min. Equivalent Length		7 ft. / 15 ft.
Number of 90° Elbows		1 / 2 / 3	115 ft. / 110 ft. / 105 ft.	Number of 90° Elbows		1 / 2 / 3
						45 ft. / 175 ft. / 170 ft. / 165 ft.

Subtract 5ft. (1.5m) for each additional 90° elbow
† For high altitude installations, consult the installation instructions.

General: Meets NAECA or EPACT Requirements, as applicable. All gas water heaters are certified at 300 PSI (2068 kPa) test pressure and 150 PSI (1034 kPa) working pressure. All water connections are 3/4" (19mm) NPT, all gas connections are 1/2" (13mm). All models design-certified by CSA International (formerly AGA/CGA), ANSI Z21.10.1 and/or Z21.10.3 and peak performance rated.

Dimensions and specifications subject to change without notice in accordance with our policy of continuous product improvement.

Suitable for Water (Potable) Heating and Space Heating. Toxic chemicals, such as those used for boiler treatment, shall NEVER be introduced into this system. This unit may NEVER be connected to any existing heating system or component(s) previously used with a non-potable water heating appliance.

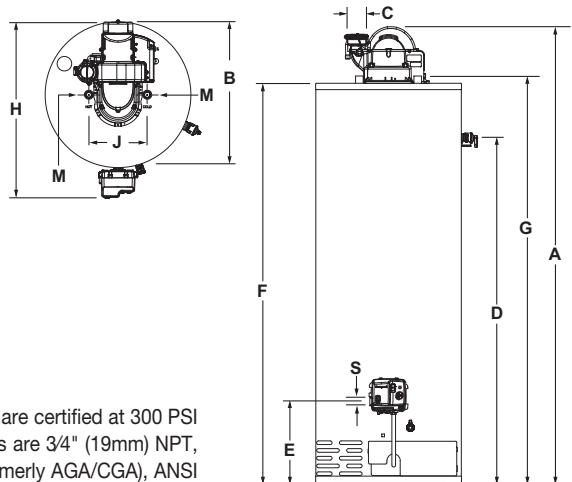

— BRADFORD WHITE IS —



For field service, contact your professional installer or local Bradford White sales representative.

Sales 800-523-2931 ■ Fax 215-641-1612

Technical Support 800-334-3393 ■ Email techserv@bradfordwhite.com

Warranty 800-531-2111 ■ Email warranty@bradfordwhite.com

International: Telephone 1-215-641-9400 ■ Email international@bradfordwhite.com / www.bradfordwhite.com

Built to be the Best®